

# BALUSTRADE 6", 7" and 12" Systems

## Tools Required For Installation:



### NEWEL POST INSTALLATION KIT

(Order 1 Kit per Newel Post)

Read through entire installation instructions before starting installation.

Dixie-Pacific™ has developed one installation kit for wood and concrete so there is no need to specify when ordering.

### NEWEL INSTALLATION KIT INCLUDES:

(ILLUSTRATION 1)

- One 4" x 4" floor flange
- Four 5/16" x 2" lag bolts
- Four 5/16" washers
- Four 1/4" x 3/4" concrete anchors
- Four 1/4" x 3/4" hex head bolts
- One 1/2" x 54" threaded rod
- One 1/2" lock washer
- One 1/2" nut
- One "C" channel

ILLUSTRATION 1

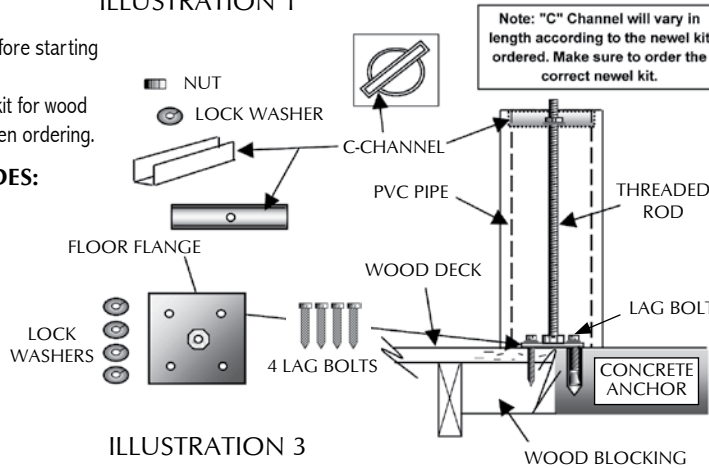

ILLUSTRATION 2



### RAILING INSTALLATION KITS

(Order 1 Kit per Top and Bottom Rail Section)

NOTE: Dixie-Pacific™ has one Standard Rail Kit for all applications (stair, straight, column attachments, etc.)

### STANDARD RAIL INSTALLATION KIT INCLUDES: (ILLUSTRATION 2)

- Twenty-Four #12 x 4" self tapping flathead screws
- One 10 oz. tube of polyurethane adhesive.

ILLUSTRATION 3

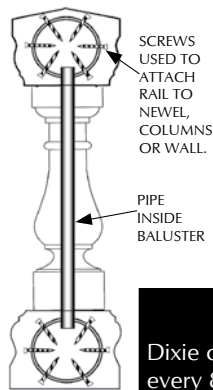

ILLUSTRATION 4

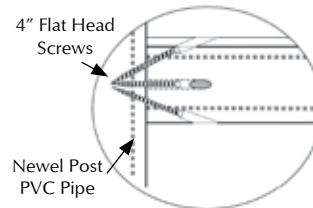
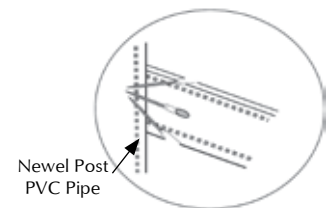

ILLUSTRATION 5



### NEWEL POST INSTALLATION

Dixie-Pacific™ has one Installation Kit for wood decks and concrete

#### 1-A. Wood Deck Installation (Illustration A)

1. Locate the center point for each newel post and floor flange.
2. Make sure to install blocking under floor flange area.
3. Secure floor flange in place with 5/16" x 2" lag bolts and washers.

#### 1-B. Concrete Installation (Illustration B)

1. Locate the center point for each newel post and floor flange.
2. Make sure the concrete is fully cured before drilling anchor holes.
3. Mark out anchor holes in floor flange. Drill 3/8" hole 1" deep.
4. Insert anchor and set anchor pin using a punch. (See Detail B)
5. Secure floor flanges in place using 1/4" anchor bolts and washers.

- 1-C. Put the newel post in place over the floor flange and screw in the 1/2" threaded rod into the nut welded to the floor flange. Put the C-channel in place and secure loosely with the nut and lock washer. The newel is secured in place after the rail section is put in place. (Illustration C)

NOTE: When applying a flat cap and ball to the newel post use the threaded rod as a dowel to provide extra strength to the ball (Illustration M)

ILLUSTRATION A

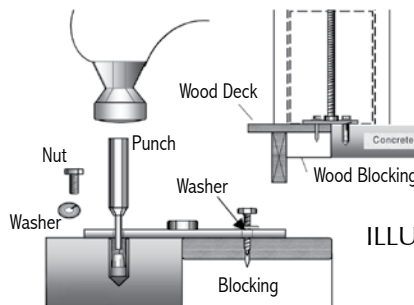

ILLUSTRATION B

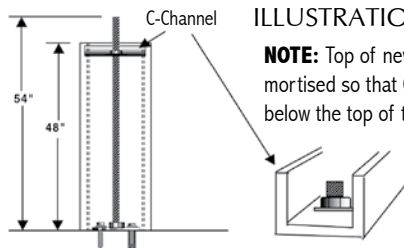
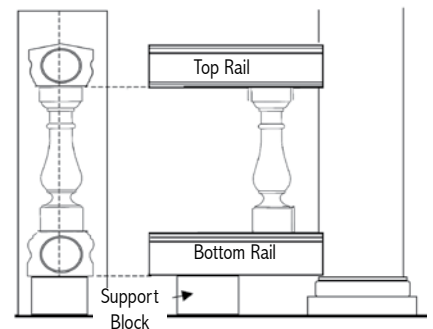

ILLUSTRATION C

NOTE: Top of newel post comes mortised so that C-channel sits below the top of the newel post.

ILLUSTRATION D



NOTE: All DuraCast™ Columns must be pre-drilled using 1/8" drill bit.

## IMPORTANT

Dixie curved balustrade railings use serrated PVC pipe. Newel posts must be used every 8 feet and a support block must be used at the center point of the bottom rail. Rails are not designed to butt into each other; they are designed to be joined to newel posts. Any other application will not be covered by warranty.

**RAIL & BALUSTER INSTRUCTION  
PREPARATION & ASSEMBLY**

- Additional baluster and rail assembly tools. 3-6 nylon straps.
- 2-A. Locate and mark center line on the newel post or column. (Illustration D)
  - 2-B. Complying with code, cut the support blocks to the desired height of the bottom of the bottom rail and set them in place between the newel posts. Support blocks should be used when spanning more than four feet. For 8' rail sections use one support block. For 10' and 12' sections use two or more support blocks. (Illustration D)
  - 2-C. Measure the distance between newel posts or columns. (Illustration D) Cut and/or cope the rails to length working with the bottom rail first.
  - 2-D. Lay out the center line spacing for the balusters on the top and bottom rail section. Refer to the pipe in the baluster for the proper hole size and drill the holes in the rail accordingly. (Illustration F)
- NOTE: Make sure to take measurements from both the top and bottom of the newel post or column before cutting rails to length. Make sure the system is square. The top rail may be longer than the bottom rail when installing between tapered columns.
3. Set the bottom rail in place between the newel posts or columns.
  4. Rough up the top and bottom of each baluster and the areas around the baluster holes in the top and bottom rails. Use a heavy grit sand paper, sanding disk or Dremel tool to expose the yellow foam core to ensure the polyurethane adhesive will have a good surface to bond to. (Illustration G)
  5. Apply a 1/2" bead of urethane adhesive to the bottom of each baluster and put into place on the bottom rail. (Illustration G)
  6. Apply a 1/2" bead of urethane adhesive to the top of each baluster and put the top rail in place. (Illustration G)
  7. Twist each baluster to ensure the adhesive contacts the rails surfaces.
  8. Strap the assembled rail section together loosely. Use cardboard material to place under the straps to protect the rail from strap marks. (Illustration H)
  9. Use a tape measure or square to align all the balusters with the edge of the rail. (Illustration I)
  10. Tighten straps on rail assembly and clean any excess adhesive from around the balusters using a putty knife and towel. (Illustration K)
  11. Using a pencil, outline the top and bottom rail on each newel post or column.
  12. Remove the strapped rail section and rough up the areas where the rails meet the newel post or column.
  13. Apply a 1/2" bead of adhesive to the four ends of the assembled rail section. (Illustration J) Set the rail section back in place and secure in place using six-4" self tapping screws. (Illustration K) Clean any excess adhesive from the area around the end of each rail.
  14. Secure the newel posts in place by tightening down the 1/2" nut. (Illustration L)
  15. If applying a peak or flat cap, cut the threaded rod flush with the top of the newel post. If applying a ball cap, drill a 1/2" hole in the bottom of the ball and cap. Set cap and ball over threaded rod. Use adhesive and screws to secure cap and ball in place. (Illustration M)
  16. All screw holes should be filled using two part plastic wood filler.
  17. All joints should be caulked using any quality latex caulk.
  18. Spot prime using Kilz® oil-base or latex primer.
  19. Paint using any quality latex or oil base paint.

ILLUSTRATION E

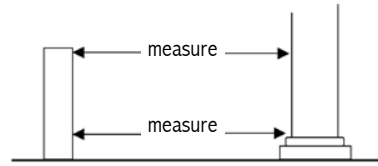

Note: Check local building codes for baluster spacing requirements and required rail height.

ILLUSTRATION F



ILLUSTRATION G

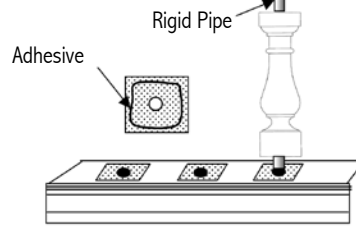

ILLUSTRATION H

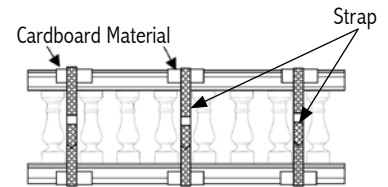

ILLUSTRATION I

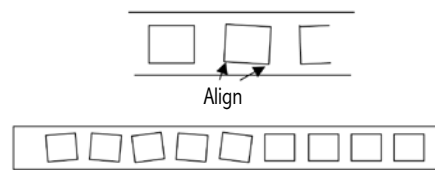

ILLUSTRATION J

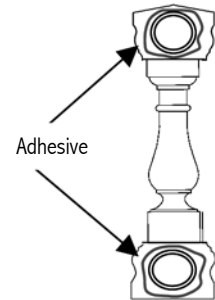
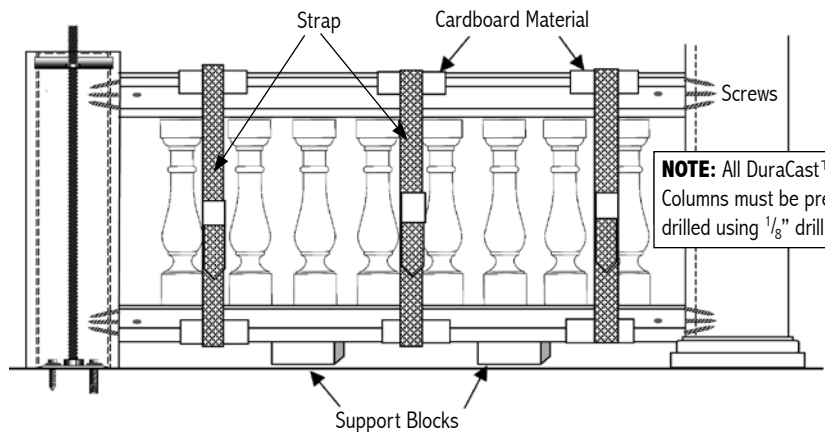

ILLUSTRATION K



NOTE: All DuraCast™ Columns must be pre-drilled using 1/8" drill bit.

ILLUSTRATION L

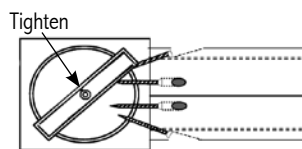
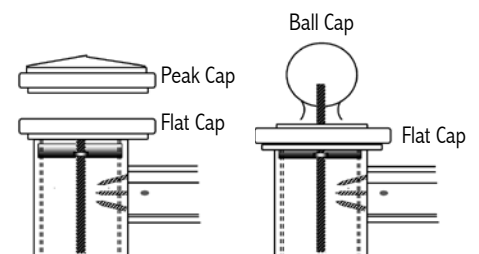

ILLUSTRATION M



**Warranty is void if installation instructions are not followed.**

**NOTE:** Installation and the structural integrity of the balustrade system is the responsibility of the installer. Dixie-Pacific™ will not be held liable or responsible for installations that do not meet national, international, or local building code requirements.